



INSTRUCTION MANUAL

Joëlette[®]
ADVENTURE

Joëlette[®]
eMOTION

C10P148-C10P153 . Rev D . 30-09-2024.

This manual must be given to the user of the product. before using this product, read this manual and save for future reference.

Non-contractual pictures

INTRODUCTION	P. 4
USABILITY	P. 4
WARRANTY	P. 5
JOËLETTE	P. 5
HOW TO OPERATE A JOËLETTE	P. 6
GENERAL INFORMATION	P. 6
<u>The team</u>	p. 6
<u>The back guide</u>	p. 6
<u>The front guide</u>	p. 7
<u>The third guide</u>	p. 8
<u>The passenger</u>	p. 8
<u>Shock absorber</u>	p. 9
SPECIFIC TECHNICAL HANDLING	P. 10
<u>Going upwards</u>	p. 10
<u>Going downwards</u>	p. 10
<u>Difficult trails</u>	p. 11
<u>Curves</u>	p. 12
<u>Cross slopes</u>	p. 12
INSTALLATION OF THE PASSENGER OF THE JOËLETTE	P. 12
<u>Transfer</u>	p. 12
<u>Passenger's security and support</u>	p. 13
<u>Comfort</u>	p. 14
START AND STOP	p. 14
<u>Placing the Joëlette on its wheel</u>	p. 14
<u>Placing the Joëlette on its supports</u>	p. 15
SECURITY INSTRUCTIONS	P. 16
<u>Choice of trails</u>	p. 16
<u>The team</u>	p. 16
<u>Preparing the hike</u>	p. 16
<u>Insurrance</u>	p. 16
<u>Rucksack</u>	p. 16
<u>During the hike</u>	p. 17
JOËLETTE ADVENTURE	P. 18
INTRODUCTION	P. 18
EXPLODED VIEW OF THE JOËLETTE ADVENTURE	P. 19

UNFOLDING THE JOËLETTE ADVENTURE	P. 20
JOËLETTE eMOTION (WITH ELECTRICAL ASSISTANCE)	P. 23
INTRODUCTION	P. 23
MOTOR CHARACTERISTICS.....	P. 23
OPERATING INSTRUCTIONS FOR THE SELECTOR AND THE DISPLAY.....	P. 23
HOW TO USE THE BATTERIES	P. 25
<u>General operating instructions and recommendations</u>	P. 25
<u>Battery characteristics.....</u>	p. 25
<u>Batteries connection</u>	p. 26
<u>Using the batteries</u>	p. 26
<u>How to charge the batteries.....</u>	p. 27
<u>Tips for charging your battery.....</u>	p. 27
<u>Storage, maintenance and transport</u>	p. 27
CHARGER OPERATING INSTRUCTIONS	P. 28
<u>General operating instructions and recommendations</u>	p. 28
<u>Operating instructions.....</u>	p. 28
SAFETY INFORMATION ON THE ELECTRICAL SYSTEM	P. 28
SAFETY INFORMATION REGARDING MAINTENANCE	P. 31
EXPLODED VIEW OF THE JOËLETTE eMOTION	P. 32
UNFOLDING THE JOËLETTE eMOTION	P. 33
MAINTENANCE	P. 34
MAINTENANCE	P. 34
CLEANING.....	P. 34
DISINFECTION.....	P. 35
INSPECTION CHECKS	P. 35
LONG-TERM STORAGE	P. 36
SHOCK ABSORBER ADJUSTMENT	P. 36
AFTER USE	P. 37
DISPOSAL	P. 37
TECHNICAL DATA	P. 38
ASSEMBLY OF THE HEADREST	P. 40
ASSEMBLY OF THE ADVERTISING SUPPORT	P. 41
CONTACT.....	P. 43

INTRODUCTION

This user manual contains important information about the handling of the product. In order to ensure safety when using the product, read the user manual carefully and follow the safety instructions.

Note that there may be sections in this user manual, which are not relevant to your old generation Joëlette, since this manual only applies to Joëlette commercialized from 2023. Please ask Joëlette and Co to get the manual of a former version.

If you find that the font size in the print version of the user manual is difficult to read, you can download the pdf from the website www.joeletteandco.com. The pdf can then be scaled on screen to a font size that is more comfortable for you.



USABILITY

Only use the Joëlette when it is in perfect working order. Otherwise, you might put yourself and others at risk. The following list does not claim to be exhaustive. It is only intended to show some of the situations that could affect the usability of your Joëlette.

You should immediately stop using the Joëlette if its usability is restricted due to:

- Damage to the braking system
- Damage to the seat locking system
- Damage to the electrical system (Joëlette eMotion)
- Insufficient tire pressure
- Damage to the front arms
- Damage to the footrest
- Damage to the belt and holding system
- Cables that are damaged, kinked, pinched or have come loose from the fixation
- Missing safety pins
- Unusual sounds developing or occurring

WARRANTY

The Joëlette comes with a two years warranty. The Joëlette must be used in strict accordance with the intended use, maintenance and service requirements as set out in this document. Risk of accident and loss of warranty if maintenance is insufficient (page 32). The availability of spare parts is limited to **5 years**.

For reasons of safety and in order to avoid accidents which result from unnoticed wear, it is important that the Joëlette undergoes a multiannual inspection and minimum once every year under normal operating conditions. Under regular operating conditions, it would be expedient to carry out intermediate checks on the brakes, accessories and running gear.

If you encounter a malfunctioning problem on your Joëlette, do not intervene yourself at the risk of losing the guarantee, contact us. Any damage or error resulting from the non-observance of this manual or poor maintenance is excluded from the warranty. Do not try to carry out any work or manipulation that is not described.

JOËLETTE

The hiking chair named «Joëlette» is an all-terrain one-wheeled chair that enables mobility-challenged people to get involved into hiking and running activities, even on the rockiest trails and roughest terrains.

Thanks to its unique wheel and suspension system, the chair enables the access to the roughest terrains so far inaccessible with a classic wheelchair both off and on the trail!

A back handle and a front pair of arms enables the two guides to handle it easily as the weight of the passenger lies on the wheel!

From leisurely walks to adventure races and even marathons, the Joëlette adapts to all outdoor activities. Only the physical capacity of the guides, runners or hikers, makes the limits of a Joëlette.

The Joëlette is designed for a wide range of users with different needs.

The use of the Joëlette is under the full responsibility of the accompanying persons.

The Joëlette Adventure is the classic single-wheel model. It is differentiated from the Joëlette eMotion, which has an electric assistance. The driving techniques are the same for both models.

WARNING

The Joëlette on very uneven terrain is not recommended for physically fragile people who could suffer fractures, pain or musculoskeletal deformations following major shocks or vibrations (passage of steps, stones/rocks).

Any serious incident related to the use of the Joëlette must be reported to the manufacturer.

ONLY FOR LEISURE ACTIVITIES

HOW TO OPERATE A JOËLETTE

In order to make sure that the passenger is in security, the guides should be in a good physical condition.

However, you needn't be a « professional » sportsman to operate it. The Joëlette can also be used for peaceful strolls and walks on easier paths.

Operating a Joëlette requires some technical skills and a little training in the beginning. For this reason, we suggest that you start using the Joëlette on easy terrain and then you can progressively increase the degree of difficulty.



GENERAL INFORMATION

THE TEAM

The number of drivers needed to drive a Joëlette can vary from 2 to 5 people depending on the difficulty of the route, the driving experience of the drivers and the weight of the passenger.

The standard Joëlette crew is composed of one passenger and two drivers. With experience and if the route is not difficult and the passenger light, it is possible to have only two drivers per Joëlette.

Each pilot has a precise role to play depending on where he is placed. The key to success for a good driving of the Joëlette is that each teammate fulfils his specific role as described below, so that the efforts of each one complement each other and add up to an optimised driving.

THE BACK GUIDE

The main role of the rear guide is to ensure the balance of the Joëlette. This balancing is done by finding the balance point corresponding to the lateral balance and the front/rear balance. This balance point must be maintained and readjusted continuously by the guide, as the Joëlette progresses.

The rear guide ensures that the passenger sits correctly: the seat is always horizontal and tilted backwards very slightly.



This position guarantees a comfortable seat for the passenger and also ensures that the Joëlette is well positioned on its balance point. Once the balance point is found, the rear guide uses the rear handlebar adjustment system to have the handles at the height of his pelvis:

- A rear handlebar position below the pelvis is uncomfortable for the rider who has to bend
- A position of the rear handlebars above the pelvis does not guarantee good safety, especially with regard to the risk of «front tipping» of the Joëlette



Handlebars too low



Handlebars too high



Good handlebar position

To adjust the height of the handlebars, the front guide holds the arms firmly to ensure the balance of the Joëlette. The rear guide can, if necessary, hold the backrest with his right hand and adjust the height of the rear handlebar with the small left handle, raising or lowering it a few notches depending on the terrain.

If the terrain changes, the rear guide will adjust the rear handlebar setting. When riding downhill, he raises the rear handlebars upwards. Conversely, on uphill, he will make the opposite adjustment.

- Going downwards, the rear guide is responsible for braking (right handle).
- Going upwards, if necessary he can push with his arms or with his pelvis on the rear handlebar.

THE FRONT GUIDE

The front guide selects the route. He observes the terrain in front of him and chooses the smoothest route for the wheel to pass, avoiding obstacles where possible or going around them. When going around obstacles, he must take into account that the wheel is a good metre behind him. If he cannot avoid them, he shall signal the obstacles to the passenger and the rear guide.

WARNING

The rear handlebar must always be adjusted when the bike is stationary. If you are walking, there is a risk of tipping backwards. Be careful not to confuse the left handle (handlebar adjustment) with the right handle (braking).





He has the role of the motor: he brings the traction energy to make the Joëlette move forward. The most efficient traction is done with the body leaning forward, slightly out of the arms of the Joëlette, the arms stretched backwards pulling the sticks.

He can also be equipped with a traction harness allowing him to pull with the whole weight of his chest (delivered with the Joëlette).

In his pulling energy, he must not in any way upset the balance defined by the rear pilot. He does not intervene in the maintenance of the balance of the Joëlette, (except in exceptional case related to safety, in support of the rear pilot) or to allow the rear pilot to adjust his handlebar.

THE THIRD GUIDE

He is there to take over from one of the riders when fatigue is felt.

He ensures the parade and the safety in the delicate passages.

He helps to pull the Joëlette in steep climbs by positioning himself in front of the front rider and pulling with the help of a strap that is fixed inside the front arms (also delivered with the Joëlette).

He can also help with the traction or the passage of obstacles by positioning himself laterally at the level of the passenger and by pulling the Joëlette at the level of the armrests or the side handles provided in option (while taking care not to destabilize the lateral balance of the Joëlette).

He is free to move around as he does not pilot the Joëlette, which allows him to carry out a multitude of small tasks that the other attendants cannot do: helping the passenger, taking something out of the pilots' bag, opening and closing a barrier...

THE PASSENGER

In the centre of the Joëlette, he feels everything! He must signal to his teammates if he feels any imbalance in the driving of the Joëlette. If the passenger feels imbalances, it is a discomfort for him that must be corrected, but it also means that his riders are not in the right position and must therefore be in an uncomfortable situation too.

The process of getting on a Joëlette is not trivial for a disabled person. It implies that he/she gives up the autonomy he/she can have with his/her manual or electric wheelchair and relies entirely on his/her teammates for his/her mobility and safety!

Even severely disabled people can use the Joëlette thanks to the possibility of integrating a shell.



To do this, simply remove the original cushions and install the shell on the seat by passing the shell's attachment system behind the backrest straps. The majority of the shells fit on the Joëlette in its most extended position, an adjustment that must be made when the arms are mounted.

There are many different types of disabilities, so the pilots must set up possible adaptations (straps, cushions, foams...) beforehand to ensure the comfort of everyone.

The Joëlette can support a weight of **110 kilos**. However, for safety reasons, the weight of the passenger should not greatly exceed the weight of the back rider (to be adjusted according to the capacities of the team as well as the difficulty of the route).

SHOCK ABSORBER

Your Joëlette is delivered with its shock absorber set to a pressure of 13 bars, for passengers weighing up to 85kg. This factory setting will be suitable in the vast majority of cases and we advise you to keep it if possible. However, in some cases (particularly for passengers weighing more than 90kg), you will need to adjust the internal pressure of the shock absorber to prevent it 'bottoming out'. To do this, you'll need a high-pressure pump (readily available from bicycle shops or sporting goods superstores).

For lightweight passengers, adjust the pressure between 11 and 13 bars. For passengers weighing more than 90kg and up to 110kg, the pressure can be increased up to 15 or 16 bars. Find the detailed shock absorber adjustment on **page 36**.

Adjust the pressure to the desired value, then disconnect the pump, not forgetting to screw the valve cap back on.

KEY POINTS TO REMEMBER

- **The front guide pulls the Joëlette**

He is responsible for the choice of the course, avoiding the main obstacles. He communicates with the other two pilots to ensure quality piloting. He must anticipate problems. He takes care not to upset the balance point given by the back guide.

- **The back guide balances the Joëlette**

He is responsible for the correct positioning of the Joëlette and makes sure that the Joëlette remains horizontal in order to keep the weight of the passenger above the wheel in all circumstances. He also ensures the braking so that the descents go well.

- **The side pilot does not contribute to the movement** but is a resource person to assist the pilots in the harder passages or difficult climbs and can also intervene in the event of a fall of one of the two pilots. He also acts as a link between the passenger and the pilots.

The guides of the Joëlette are there to balance and propel, but not to carry! If one or the other pilot is carrying, it is a sign that the Joëlette is not on its balance point.

The Joëlette is designed in such a way that if it is on its balance point, the passenger's seat will be good and the riders will be in a comfortable position. So never let an uncomfortable driving situation arise!

SPECIFIC TECHNICAL HANDLING

GOING UPWARDS

The front guide must ensure that he/she provides the traction effort while leaving some flexibility in the height of the arms so that the rear rider can balance.

The third guide helps to pull the Joëlette in the strong ascents by positioning himself in front of the front pilot and by pulling with a strap that is fixed inside the front arms. The strap should be around the hips and tight.

When turning, the guide must be careful to keep his pulling effort in line with the Joëlette. Pulling with the strap is most effective on slopes without large obstacles or sharp turns.

When he helps with the traction by positioning himself laterally at the level of the passenger and by pulling the Joëlette by the armrests or by the side handles (option), he must take care that his traction effort is directed in the same direction as that of the front pilot and that he does not destabilize the balance given by the rear pilot.

Depending on the steepness of the slope, a 4th or even 5th pilot may sometimes be necessary. When pushing from the rear, be careful not to tip the front arms down or up, which would cause the front rider to have difficulty.



GOING DOWNWARDS

In descent, the rear pilot must control his braking and the balance of the Joëlette, in order to avoid the risk of «front tipping» :

- Smooth braking, avoiding jerking.
- Position of hands on rear handlebars never above the pelvis.
- No significant weight difference between the passenger and the rear guide.

When going downhill, the front pilot has mainly a role of choice of itinerary; he must however remain very vigilant and listen to what is happening at the level of the back guide.

He must not hold back the Joëlette, it is the rear guide who takes care of the braking. He must be careful not to be too much tucked inside the front arms, in order to avoid his heels hitting the passenger's footbraces.

He/she must be careful never to press the front arms downwards as this could cause the Joëlette to tip forward :

- The steeper the slope, the higher the front guide's arms will be.
- In case of a very steep slope or a big step down, the front arms will reach above the armpits. In this case, the front guide must turn around to face the passenger and raise his arms as high as necessary to accompany the descent of the Joëlette.
- If the wheel of the Joëlette hits an obstacle when going downhill, the traction effort that he will provide must be done in such a way as to cross the obstacle without pulling the Joëlette downwards, always in order to avoid the «forward tilt».

DIFFICULT TRAILS

In the case of overcoming major obstacles (steps, large stones, etc.):

- An additional guide is required and must communicate with the back guide
- Be careful not to catch the passenger's feet.
- If necessary, the third guide helps by standing sideways at the passenger's height, always ensuring that his pulling force is directed in the same direction as that of the front guide and does not destabilise the balance given by the back guide.
- If a carry is required, using the front arms, the guide and attendant respectively grasp the rear handlebars and the front arms as close to the passenger as possible to reduce the reach in order to minimise the strain on the front arms.



In the case of delicate passages (narrow passages, slopes, steep slopes, etc.):

- It is important that the people setting off have stable supports so that they can really ensure the safety of the passenger as well as themselves.
- If the parachutists do not have stable support because of the terrain (narrowness, too steep a slope...), they will position themselves upstream and downstream of the difficulty, in static support, and will pass the Joëlette from hand to hand.

Whether in obstacle clearance or in parrying, a 4th or even a 5th person may sometimes be needed to support the 3rd pilot.

If the passenger is concerned about jolting, riders should not let the seat drop abruptly after passing an obstacle or going down steps, but cushion the passage of an obstacle by holding the front arms and rear handlebars slightly.

IN CURVES

- Avoid turns on the spot, a quarter turn and a half turn. Prefer wide, moving turns. When turning on the spot, warn the back rider and turn slowly, so that the back rider has time to follow the movement by turning the Joëlette without risk of imbalance.
- In narrow bends, the front rider must anticipate the position in which the rear rider will be and take the bend in such a way that the rear rider does not end up off the path in a delicate situation (slope, brushwood, tree trunk, etc.).
- If necessary, in really tight corners, riders will get into the front arms, or get out of the front arms altogether with the help of others present.

IN CROSS SLOPES

In a sideways situation, the Joëlette must be kept in its vertical axis, so that the passenger's weight rests fully on the wheel. This is how the best grip of the wheel on the ground will be maintained. This is the best way to maintain the wheel's grip on the ground.

Here are the basics of driving a Joëlette. It's up to you to experiment, starting with easy routes and gradually increasing the difficulty.

Above all, remember that the priority is to ensure the comfort and safety of your passenger, while having fun!

INSTALLATION OF THE PASSENGER ON THE JOËLETTE

THE TRANSFER

Since the new generation model, the transfer of the passenger on the Joëlette is facilitated since the seat is at standard wheelchair height.

Make sure that the Joëlette is positioned in a fully stabilised way. The front and rear attendants help the passenger to get into the seat. If necessary, a third person can be positioned at the back of the Joëlette to ensure its stability.

- If possible, and with the support of the companions if necessary, the passenger moves forward between the front arms of the Joëlette to the footrests and makes a half-turn so that his back is to the seat. If possible, he/she lifts himself/herself up by leaning on the armrests of the seat (be careful not to lean too much on the footrests which are not designed to support the whole weight of a person!).

- It is also possible to retract one of the two front arms in order to make an autonomous lateral transfer from the wheelchair to the Joëlette.
- If the passenger cannot get into the seat by himself, the accompanying persons will help him by positioning themselves on one side of the Joëlette and lifting him into the seat.

A common carrying technique is for carers to put their neck under the armpit of the passenger, with one hand behind the back holding the belt and the other hand under the knees and then lift together. Other transfer techniques exist, such as the use of a lift.

If the passenger is in a shell, he/she can be transferred with the shell to the Joëlette. To do this, detach the cushions and use the original attachment system of the shell.

In any case, remember to take it easy when lifting the person: carry by bending the legs. Also make sure that your transfer technique is suitable for the person with a disability. Don't hesitate to ask for advice: she knows her disability best and will be able to tell you what kind of help she needs and what is not suitable.

PASSENGER'S SECURITY AND SUPPORT

- Before each ride, buckle the chest protector. Be careful to position it correctly on the passenger (no twisting, clothes underneath, not too tight) so as not to create discomfort.
- Adjust the height of the footrests using the tightening handle located between the two footrests. Tighten the handle after the footrest has been adjusted.
- Attach the feet to the footrests using the velcro strips provided.
- Adjust the inclination of the footboards using the 3mm Allen key provided.
- Adjust the headrest to the correct height (resting against the user's neck) using the knob. If the headrest is in the wrong position, a collision may cause the neck to hyperextend. Tighten the handle after the headrest has been adjusted.



COMFORT

Ensure that the passenger is as comfortable as possible from the outset:

- By adjusting the footrest and headrest as much as possible. The inclination of the backrest can also be adjusted in three positions (front, normal and rear). This adjustment is to be anticipated because it is done when mounting the arms of the Joëlette with the help of the three tapped holes, on both sides of the seat.
- Make sure that the passenger's clothes and limbs are in the right position (during the transfer they may have become crooked).
- Beware of the risk of injury if an item (limb, clothing, etc.) comes into contact with moving parts.

STARTING AND STOPPING OF THE JOËLETTE

PLACING THE JOËLETTE ON ITS WHEEL

The wheeling process can begin when only the footrests and rear supports are in contact with the ground.

1• The front attendant positions himself on the inside of the arms, facing the passenger, and holds both arms firmly. He then takes hold of the locking lever under the seat on his right and turns it 180° to the left. This locks the seat automatically before the start of the journey. If you forget to do this, always check that the locking lever is pointing upwards.

2• The rear steward adjusts his handlebars by positioning himself on one of the three upper holes of the adjustment system so that it is approximately in line with his outstretched arms. He then applies the brake. **It is imperative that the brake be applied until the wheeling process is complete.**

3• The rear attendant tilts his or her upper body backwards, while at the same time pushing backwards so that the wheel makes contact with the ground. At the same time, the front attendant relieves the weight by moving forward towards the passenger until the seat locks. **The transfer process is completed when a «click» is heard. This «click» indicates that the seat is correctly locked. If in doubt, check that the locking lever is pointing upwards or apply the brake strongly with a small forward push.**



PLACING THE JOËLETTE ON ITS SUPPORT

Choose a flat and stable site.

- 1•** The front attendant is on the inside of the arms, facing the passenger. He then takes hold of the locking lever and rotates it 180° to the right to release the seat.
- 2•** The front attendant is always on the inside of the arms, facing the passenger, and holds both arms.
- 3•** The rider adjusts his handlebar so that it is approximately in line with his outstretched arms and applies the brake.
- 4•** The rear guide gives a forward push to start the descent, **while keeping the brake on until the end of the process.**
- 5•** The front supporter holds the arms until the feet are in contact with the ground.
- 6•** The passenger is safe, the attendants can let go of the stretchers, while remaining vigilant.

Two priority rules to remember:

- Wheeling or standing: keep the brake on throughout the process.**
- Before each start: check that the locking lever is pointing upwards.**



SECURITY INSTRUCTIONS

CHOICE OF TRAILS

Before leaving on a Joëlette tour, you must identify the route you are going to take. Indeed, obstacles that are easy to cross on foot, almost without noticing, can become very technical or even impassable for a Joëlette.

However, do not think that only forest tracks are accessible, far from it. Many trails, in the plains or in the mountains, can be used with a Joëlette!

A good way to have an idea of the difficulty of a route is to ride it on a mountain bike: the Joëlette goes everywhere where a bike can go. In the same way, each obstacle, stone, root, step, rut, tree trunk requires a technical control and an additional physical effort.

THE TEAM

- The number of drivers needed to drive a Joëlette can vary from 2 to 5 people depending on the difficulty of the route, the driving experience of the drivers and the weight of the passenger. The standard Joëlette crew is composed of one passenger and two drivers.
- Drivers who are physically able to perform their role in driving the Joëlette.
- Be careful not to overestimate the physical and technical capabilities of the riders.

PREPARING THE HIKE

- Leave on a route marked in advance or referenced as accessible by Joëlette.
- Choose the route according to the physical and technical capabilities of the team of riders.
- Check that your Joëlette is in good working order. Mechanical check before the ride.
- Take note of the weather forecast. If there is a risk of thunderstorms, do not leave (because of its metal construction, the Joëlette attracts lightning). You should also know that a route that is feasible in a Joëlette in good weather can become extremely challenging in wet weather.
- Tell people around you about the route you are planning to take.

INSURANCE

It is compulsory for each accompanying person to have a civil liability insurance. The use of a Joëlette does not require specific insurance, but this practice must be reported to your insurer.

RUCKSAC

- Usual equipment for mountain trekking (map and compass, first aid kit and survival blanket, torch, water and provisions, suitable clothing...).
- Mobile phone to call for help in case of emergency (European emergency number 112 or number of the PGHM in the area).

- Repair material for the Joëlette (adapted tools, brake cable, repair kit in case of a puncture, spare inner tube or «restart quickly» spray, ...), small repair material (straps, turnbuckles...).
- For the passenger, who can quickly be in a sensitive position with regard to the cold, bring warm clothing. Don't forget to protect the extremities (gloves, hat...) and if necessary, bring a protective cover against the cold («extreme cold cover»). Also think of taking a protection against the rain of the poncho type which also allows to protect, if necessary, the passenger as well as the equipment of the Joëlette (cushions, cover big cold...).

DURING THE HIKE

- Wear a mountain bike helmet for the passenger.
- Be well-shod for the Joëlette drivers.
- Check the tightness of the stretchers, especially on routes with strong jolts, and adjust the brake before the descent.
- Maintain balance and the correct seat position at all times, regardless of slope or ground conditions.
- Adjust the height of the rear handlebars so that they are not above the pelvis.
- Do not drive the Joëlette if you feel too tired. Know how to tell and respect your own limits.
- Do not drive the Joëlette if you feel too tired. Do not go too fast: You have to know where the wheel goes, where you put your feet and do not stumble or slip. Know your limits.
- Remember to communicate with each other, especially during technical passages.
- Beware of bulky backpacks that may get caught on the stretchers (front driver).
- In cold weather, make sure that the passenger does not run the risk of hypothermia due to his immobile situation and sometimes to his pathology (circulatory problems, loss of sensitivity not allowing to feel the cold...).
- Do not leave a Joëlette in a low position without a person next to it, especially if the passenger has uncontrolled movements.
- Beware of falling in difficult passages, near a ravine, on slippery ground!
- But remember that falls don't happen in the tricky parts but rather in the quiet moments, due to lack of vigilance.
- Be careful not to go near a flame, risk of ignition of the cushions and fabrics.
- It is recommended that the passenger stand up and/or change position at least every 2 hours to limit the risk of pressure sores (coccygeal, ischial, spinal).
- Make sure that the parts of the Joëlette in contact with the passenger's skin are not excessively hot (which could lead to burns).

JOËLETTE ADVENTURE



INTRODUCTION

First of all, all instructions for driving, starting, maintenance and care of the Joëlette (page 4 to 17) also apply to the Joëlette Adventure.

The Joëlette Adventure is the latest model of the Joëlette, launched in 2023. The improvements aim to make it easier for the guides to drive and to improve the comfort of the passenger:

- It is equipped with a fatbike wheel and a latest generation shock absorber to further dampen the shocks for both the guides and the passenger.
- The handlebars have evolved to allow a better grip for the rear guide.
- The folding of the Joëlette is now more compact in order to reduce the space required.
- The weight is slightly reduced to make it easier to move around.

EXPLODED VIEW OF THE JOËLETTE ADVENTURE

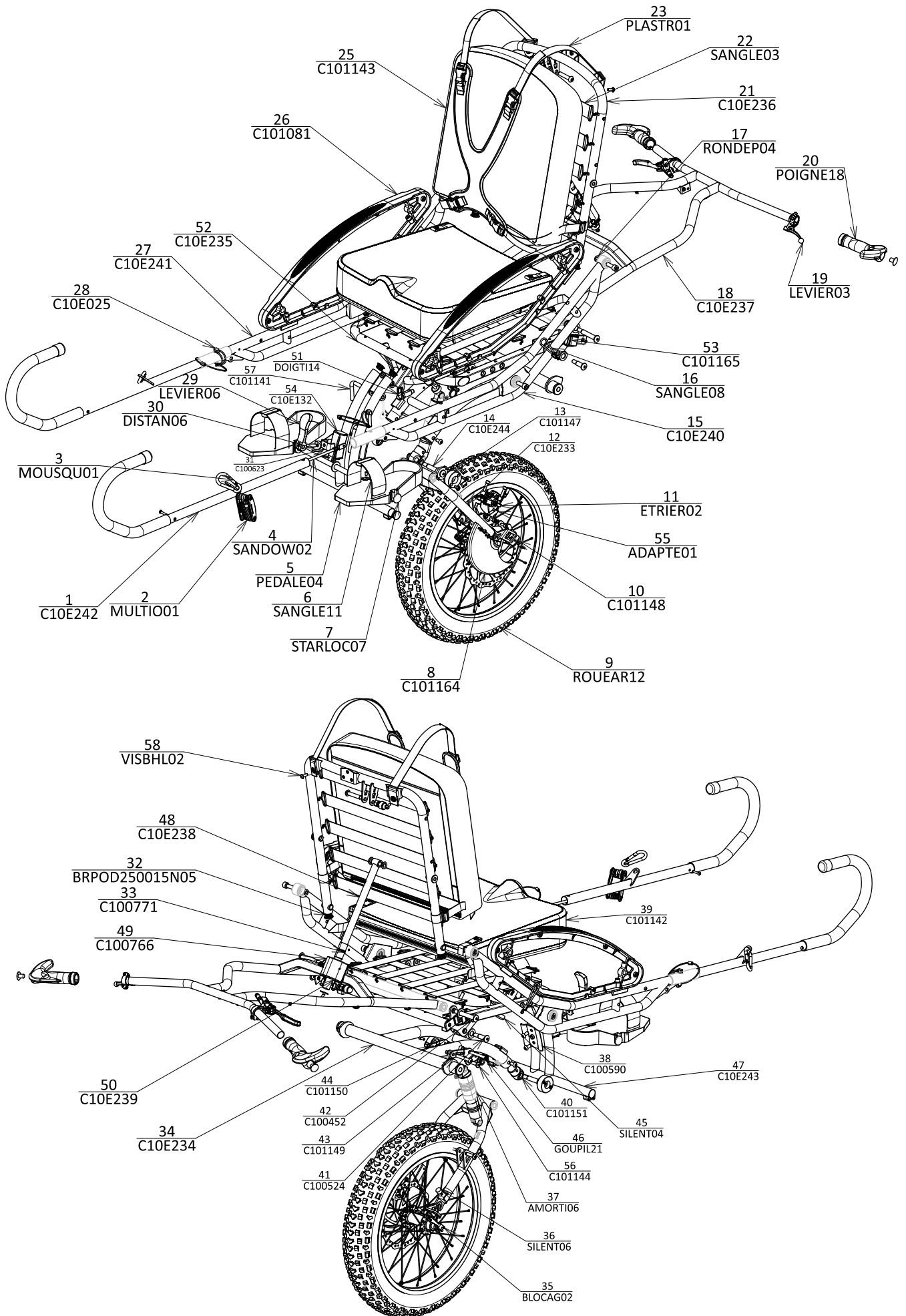

UNFOLDING THE JOËLETTE ADVENTURE



1. Remove the wheel, traction straps, front arms and cushions from the transport bag.



2. Take the footrest located in the middle of the swing arm, position it on its support and lock it with the pin.



3. Unlock the locking lever and turn the Joëlette by leaning on the handles until the rubber support pads are in contact with the ground.

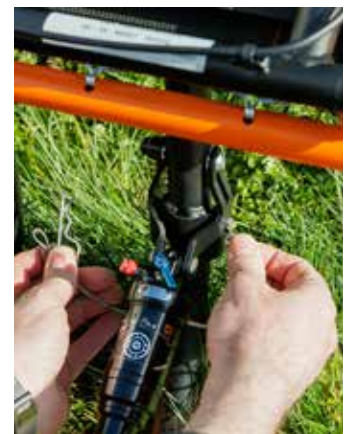

4. Remove the pin and beta pin and tilt the swingarm so that the holes in the shock mounting bracket match those in the transfer frame.

5. Pass the stainless steel pin through everything and secure the connection with the beta pin.



6. Remove the plastic wedge positioned between the pads.



7. Position the wheel between the forks of the swingarm and secure it with the quick release.



8. Unfold the backrest and lower the handlebars, using the handle on the left, to rest it on the wheel.



9. Install the two front arms with the side mounting screws.



10. Position the cushions on the seat and backrest.



11. Pass the backrest flap behind the elastic straps and secure it with the Velcro strap.



12. Fasten the side buckles sewn into the seat and fold the front panel down.



13. Unfold the arms and snap the two parts together.



14. Lock the arms with the safety pin.



Your Joëlette is ready to use.

To dismantle, proceed in reverse order, taking care not to jam or pinch hands or fingers on moving parts.

When dismantling/bending, take care not to pinch or bend the brake hose(s) and handlebar adjustment cable.

A video is available on our website.

www.joeletteandco.com

JOËLETTE eMOTION

INTRODUCTION INTRODUCTION

First of all, all the instructions for driving, starting, maintenance and care of the Joëlette (page 4 to 15) also apply to the Joëlette eMotion.

Thanks to the Joëlette eMotion, you can benefit from electric assistance and share the pleasures of effortless walking with family and friends.

Its speed is progressive thanks to the accelerator and can be limited to 3, 4 or 5 Km/h via the 5 levels of assistance accessible via the selector (user manual below). Its autonomy allows you to ride between 3 and 5 hours depending on the difference in altitude. The screen allows you to have all the information on your route.

Moreover, when the electric assistance is not activated, you will automatically switch to freewheel. The Joëlette eMotion is equipped with a motorised spoked wheel with hydraulic disc brake, a complete caliper with its support, an accelerator, a control screen and a remote selector, a controller, two batteries and a battery charger.



MOTOR CHARACTERISTICS

Brushless motor: maximum power 500 W / 36 V

The motor is protected by a temperature sensor in the event of prolonged stress. If the temperature of the coils rises sharply, the controller will reduce the power of the motor. If the temperature rise is prolonged, the controller will cut the power supply until the internal temperature drops. If you notice a decrease in power, please pause to allow the motor to cool down.

OPERATING INSTRUCTIONS FOR THE SELECTOR AND THE DISPLAY

The mode selector allows you to choose the level of assistance of the Joëlette eMotion. It is composed of three buttons:

- the **central** button is used to turn the screen on or off, with a long press
- the **+** button allows you to choose a higher level of assistance
- the **-** button allows you to choose a lower level of assistance

Levels 1 and 4 should be used on gentle terrain to save battery life. Levels 2, 3 and 5 should be used on rough terrain or where there is a significant difference in altitude.

LEVEL OF ASSISTANCE	1	2	3	4	5
SPEED	3 Km/h	3 Km/h	4 Km/h	5 Km/h	5 Km/h
POWER	70%	100%	100%	70%	100%

The screen displays information throughout your ride:



Recommendations

- If the outer casing or screen of the display has sharp parts as a result of an impact, replace it to avoid any risk of cutting.

The mode selector allows you to choose the information displayed on the screen:

- To reset the distance travelled, as well as the time of use, press the **+** button and the **-** button simultaneously with a long press
- Several odometers are available. They are displayed one after the other, each time the **central** button is pressed briefly :



Distance and time since reset



Distance and maximum speed



Distance and speed average



Distance travelled with the screen on since the purchase of the the Joëlette eMotion



Second kilometre counter to calculate the length of a second stage

The indications displayed on the screen are purely indicative and are not guaranteed in terms of accuracy.

HOW TO USE THE BATTERIES

For optimal use, care and storage of this battery, it is essential that you read and carefully follow the instructions in this manual.

General instructions for use and recommendations

- Never short-circuit the charge or discharge of the battery terminals.
- Never reverse the charging directions of the battery.
- Never touch the outer casing of the engine during or immediately after its use (risk of burns).
- Keep the battery away from excessive heat and flame. Never immerse the battery in water.
- To avoid damage to the battery, never subject it to a strong physical shock or vibration or a heavy blow.
- Never use a battery with a damaged outer casing.
- Protect the battery from water and moisture. Protect the battery charging and discharging terminals from rain and waterlogged elements.
- Under load, the outside temperature must be between 0°C and 40°C.
- When discharging, the outside temperature must be between -10°C and 40°C (below -10°C the autonomy drops).
- Do not leave the battery within the reach of children.
- When the battery is not in use, it is best to remove it from its slot and store it inside.
- If you need information about this battery and its use, please contact our sales department.
- It is strictly forbidden to open the battery container or to dismantle the battery cells yourself.
- In the event of a sudden shock to the Joëlette, the battery can be made safe for a fraction of a second. To restart the assistance, it is enough to put the battery out of power (OFF) then remove it from its support for about ten seconds. Then, put the battery back on its support and put it back on (ON).

If you do not follow all of the above instructions and recommendations, you will be responsible for any damage to this battery and will not be entitled to any warranty.

Battery characteristics

The PANASONIC Lithium-ion BOX battery has a high energy density, a high charge ratio, a long life cycle, a low self-discharge rate, no memory effect and, when normally recycled, no pollution.

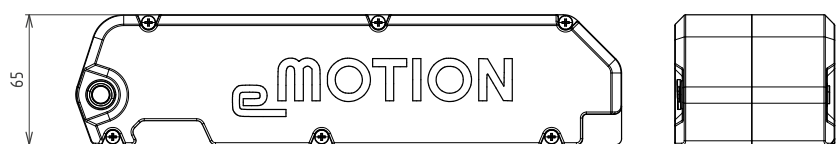

Battery dimensions

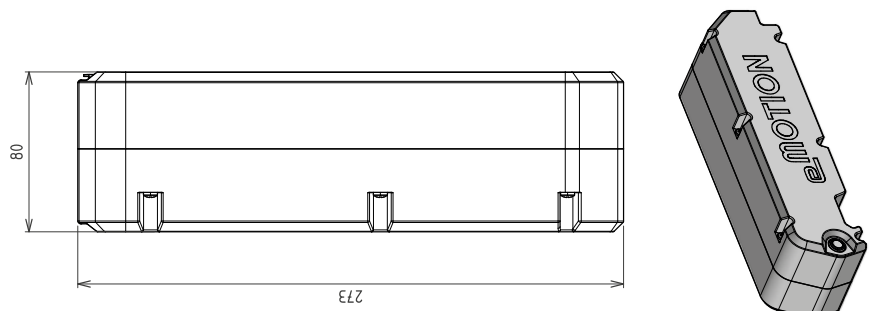

RATED VOLTAGE	36V
CAPACITY	10 Ah
CELLS	Panasonic
TECHNOLOGY	Lithium Ion
MASS OF THE BATTERY ALONE	1,756 Kg
RATED CHARGING CURRENT	3A
NOMINAL DISCHARGE CURRENT	10 A
MAXIMUM DISCHARGE CURRENT (5S)	20 A
TEMPERATURE RANGE FOR CHARGING	0°C à 40°C
TEMPERATURE RANGE FOR DISCHARGING	-10°C à 40°C
TEMPERATURE RANGE FOR STORAGE	0°C à 40°C
BATTERY POWER	360 Wh
CHARGING CONNECTOR	Jack 2,1 x 5,5 mm
DISCHARGE CONNECTOR	4 broches
ACOUSTIC POWER LEVEL	55 dB



Batteries connection

Be careful to position and lock the batteries in the battery compartment, as dropping them could cause potentially dangerous material damage.

Using the batteries

Deterioration, total destruction or explosion of one or more batteries (which may cause material and/or physical damage) may occur as a result of misuse such as :

- the use of excessively high charge or discharge currents;
- storage in extreme temperatures (below -5°C and above 35°C);
- immersion in water and fire;
- Long-term storage (more than 3 months) without charging or use;
- storage of the battery when it is discharged;
- a short circuit between the positive and negative battery terminals;
- water jet or high pressure cleaner.

How to charge the batteries

- Remove the battery from its holder
- Connect the input socket of the charger to the wall socket.
- When connecting the battery to the charger, make sure that the charger's output socket and the battery's charging socket are firmly connected. The indicator light on the charger will light up and turn red. It will turn green when the battery is fully charged.
- When the battery is fully charged, disconnect the charger from the battery before disconnecting it from the wall socket.

Tips for charging your batteries

- Do full charges to prolong the life of the batteries (i.e. do not unplug the charger until the light on the charger has turned green).
- Once the charger light has turned green, it is advisable to wait about 30 minutes before disconnecting the charger, so that the cell balancing phase can take place correctly.
- Check that at least two green lights are on. If not, charge the battery.
- Charge your battery in a dry, ventilated room or outdoors at temperatures between 0°C and 35°C.
- Connect the charger to a mains socket first, then the battery to the charger.
- When the battery is fully charged, disconnect the charger from the battery and then disconnect the mains plug.
- Wait 10 minutes after prolonged use before charging the battery.

Storage, maintenance and transport

- Never use a charger with a damaged outer casing.
- If the batteries need to be stored for a long period of time, it is preferable that their charge level is around 50%. Otherwise, charge them for 3 hours after use and store them in a dry and ventilated place. The charge level of the battery should be checked regularly.
- Both the batteries and the charger should be stored in a clean, dry and ventilated place. They should not come into contact with corrosive materials and should not be near excessive heat sources and flames.
- It is imperative to maintain a temperature range of 0 ~ 35°C and humidity conditions of 5 ~ 65% RH in the area where the battery is stored.
- During transport, the battery must be carefully packed in its box. It should be protected from strong physical shocks, strong vibrations, impacts, exposure to direct sunlight and waterlogged objects. It can be transported by car, train, boat or plane (except in the USA for air transport).
- When storing, the charger must be disconnected from the battery.
- It is imperative to maintain a temperature between 0 ~ 35°C and humidity conditions between 5 ~ 65% RH in the place where the charger is stored.
- During transport, the charger must be carefully packed in its box. It should be protected from strong physical shocks, severe vibrations, impacts, exposure to direct sunlight and waterlogged objects.

CHARGER USER'S MANUAL

General instructions for use and recommendations

- Do not place anything on the charger.
- Do not allow any liquid or metal objects to enter the charger.
- Never disassemble the charger.
- Never connect or disconnect the charger with wet hands.
- Do not connect the charger in stormy weather.
- Only use the charger supplied with the battery. It is strictly forbidden to charge the battery with other unsuitable chargers.
- Do not handle the battery or the charger during charging.
- Do not use the charger in a damp place.
- Avoid exposing the charger to direct sunlight.
- When the charger is in use, ensure that the area is well ventilated.

Operating instructions

- If your battery is equipped with an ON/OFF switch, turn the switch to the OFF position and disconnect the battery from the Joëlette.
- Connect the charger to a 220V socket with the connection
- Connect the charger to your battery with the JACK connector
- The two lights will light up red during the charge; as soon as the battery is fully charged, one light will stay red and the second will light up green.
- It is advisable to wait for about 30 minutes after the green light comes on so that the cells can be properly balanced.
- Disconnect the battery from the charger.
- Disconnect the charger from the 220V mains socket.

SAFETY INFORMATION ON THE ELECTRICAL SYSTEM



Risk of injury if the Joëlette starts up unintentionally

- Turn off the Joëlette before getting on, off or handling objects that could come into contact with the trigger because of their size, shape or weight.

 **DANGER !**

Risk of material damage or serious or fatal injury

Inappropriate use of the Joëlette may result in smoke, sparks or heat. A fire can cause damage to property and serious injury or death.

- The Joëlette must NOT be used for any purpose other than that for which it is intended.
- If the Joëlette starts to emit smoke, sparks or heat, stop using it and have it checked IMMEDIATELY.

 **CAUTION !**

Risk of fire and breakdown due to the connection of electrical appliances

- Do not connect any electrical device to your E-Joëlette that has not been expressly authorised by the manufacturer.

 **DANGER !**

Risk of material damage or serious or fatal injury

Corrosion of electrical components due to exposure to water or liquids or use by incontinent users may result in property damage or serious injury or death.

- Reduce exposure of electrical components to water and/or liquids.
- Electrical components damaged by corrosion MUST be replaced immediately.

 **DANGER !**

Danger of death or serious injury

Failure to observe these warnings may result in electrical shock causing serious injury or death or damage to the electrical system.

Do not open the battery

- Replace the cable(s) with damaged insulation immediately.

 **DANGER !**

Danger of death or serious injury

An electric shock can cause serious injury or death.

- To avoid electric shock, check the plugs and cords for cuts and frays. Replace cut or frayed cords immediately.

Risk of damage to the electrical system

A failure of the electrical system may cause unusual behaviour:

- In case of failure, remove the battery and replace it.
- If the problem persists, remove the battery and contact your dealer or the manufacturer.

DANGER !

Risk of serious injury

The electric assistance system uses components that can reach high temperatures during operation. Some parts of these components may be accessible to users, so it is essential not to come into contact with them. In particular, do not touch the wheel-motor casings or batteries during or immediately after use.

DANGER !

Risk of material damage or serious or fatal injury

Trigger malfunction may result in unexpected/erratic movement resulting in property damage or serious injury or death

- If unexpected or erratic movement occurs, stop using the Joëlette immediately and contact the manufacturer or your dealer.

CAUTION !

Risk of failure in adverse weather conditions (extreme cold or heat, isolated area)

- We advise you NOT to travel in adverse weather conditions.

Safety advice on electromagnetic compatibility

Electromagnetic fields, such as those produced by radio and television transmitters, radios and mobile phones, may affect the operation of electrical equipment. The electronics used in our electrical equipment may also cause slight electromagnetic interference, but this is below the legal limit. Please note the following information.

CAUTION !

Risk of malfunction due to electromagnetic emissions

- Do not use hand-held transmitters or communication devices (e.g. radios or mobile phones) or, as the case may be, do not use them while the equipment is in operation.
- Avoid the proximity of powerful radio or television transmitters.
- If your equipment should start moving by itself, take the Joëlette out of service.
- Adding electrical and other accessories or modifying the equipment may make it subject to electromagnetic emissions / failure. Bear in mind that there is no really safe method of determining the effect of such modifications on interference resistance.
- Report any unwanted movements of the equipment that have occurred to the manufacturer.

SAFETY INFORMATION REGARDING MAINTENANCE

This product has been strictly tested and none of the parts that make up this battery are previously used or repaired parts. If you have any questions, please contact our service department. Do not forget to bring your purchase invoice with you. It is strictly forbidden to disassemble and reassemble the battery yourself. If you do not follow all the instructions and recommendations, you will be responsible for any damage caused to these products and will not be entitled to any guarantee. In order to improve the quality and performance of our product, we have the authority to change some of its features or its manual without having to inform customers who purchased our products prior to the changes being made.



DANGER !

Risk of material damage or serious or fatal injury

Incorrect repair and/or maintenance of the Joëlette by users/carers or by unqualified technicians may result in material damage or serious injury, even death.

- **DO NOT** perform any maintenance tasks other than those described in this user manual.

Such repairs and/or maintenance **MUST** be carried out by the manufacturer or competent personnel.

Electronic protection system

The electric drive is equipped with an overload protection.

If the engine is overloaded for a long period of time (e.g. during a steep climb), especially in high outdoor temperatures, the electronic system may overheat. In such a case, the performance of this equipment will gradually decrease until it stops completely. The system disconnects and goes into safety mode. Switch off the system, wait a few minutes and then switch it on again. Note, however, that it may take some time (5 minutes) for the electronics to cool down sufficiently and for the engines to be fully operational.

If the engine is blocked due to an insurmountable obstacle, and the rider tries to force his way through for more than 20 seconds, the electronic system will disconnect the engine to prevent damage.

Turn off the electronic control equipment, then turn it back on and fly around the obstacle.

It is essential to check the entire electrical system before replacing a defective main fuse. Replacement must be carried out by the manufacturer. The equipment is protected by fuses built into the battery.

EXPLODED VIEW OF THE JOËLETTE eMOTION

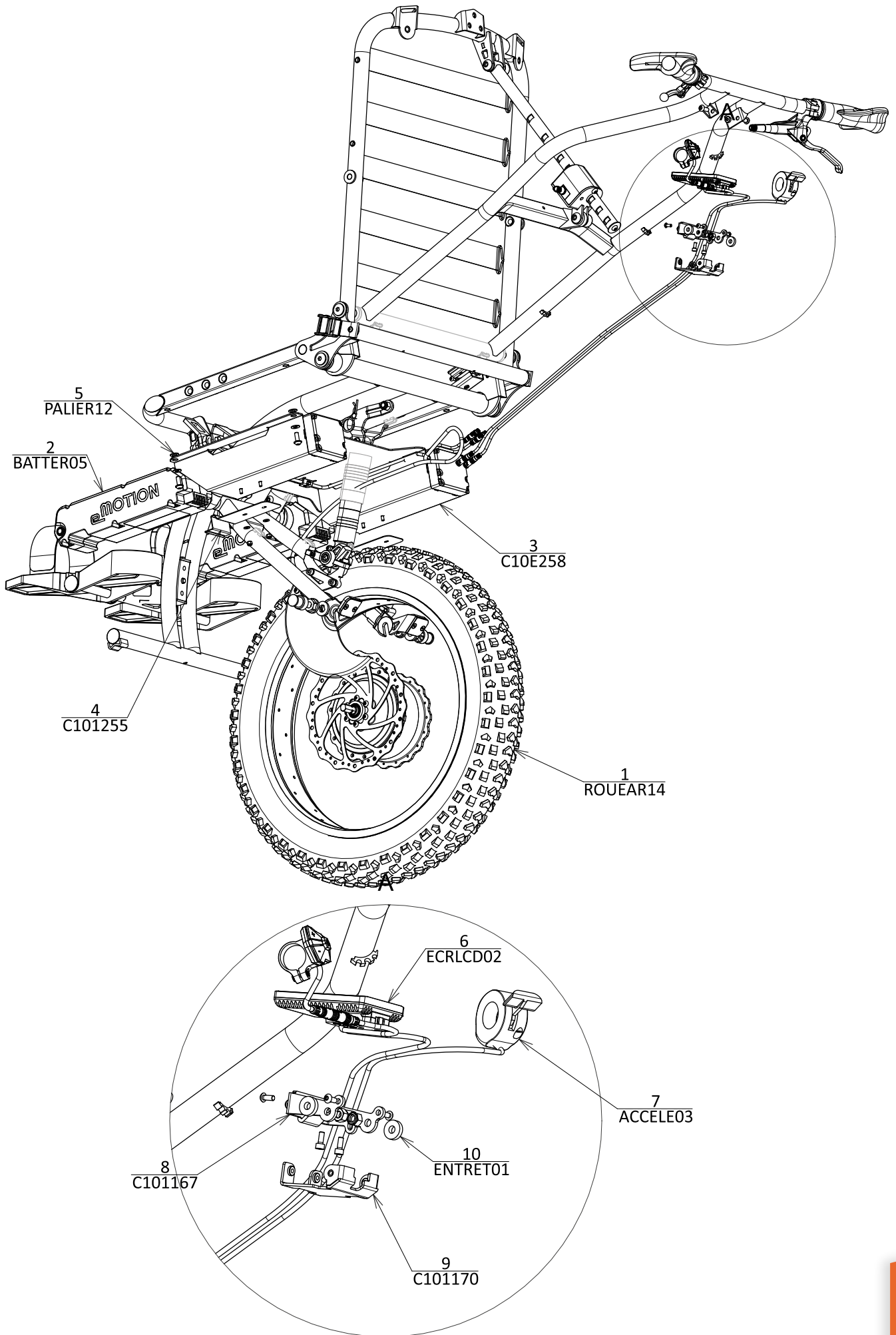

ASSEMBLY OF THE JOËLETTE eMOTION

1. To assemble the Joëlette eMotion, first follow **steps 1 to 7** of the Joëlette Adventure assembly (page 20).



2. Insert the wheel into the grooves of the fork (disc on the left). The power cable must be directed to the front of the Joëlette.



3. Place the two pin washers in contact with the outside of the fork with **the pin inserted in the front of the groove.**



4. Tighten the nuts (18 mm open-end or eye spanner). The tightening torque must be sufficient (50Nm).



5. Connect the motor power cable. Make sure that the arrows on the two plugs match.

6. Carry out **steps 8 to 14** of the Joëlette Adventure assembly (page 21 and 22).



7. Slide the two batteries into the battery compartment under the seat.

Your Joëlette is ready to use.

To dismantle, proceed in reverse order, taking care not to jam or pinch hands or fingers on moving parts.

When dismantling/bending, take care not to pinch or bend the brake hose(s) and handlebar adjustment cable.

**A video is available
on our website**

www.joëletteandco.com

MAINTENANCE

CARE AND MAINTENANCE

The term «Maintenance» refers to any activity that keeps the Joëlette in good condition and ensures its fitness for travel. Maintenance includes different areas such as regular cleaning, inspections, repairs and general servicing.

It should be done at least once a year regardless of the frequency of use. A second maintenance is necessary in case of regular use (several times a week).

The maintenance to be planned is practically the same as for a mountain bike.

It consists of checking :

- tyre pressure
- the correct operation of the braking system, in particular the condition of the brake pad linings. A brake lever that is a bit «soft» does not ensure optimal braking. The lever must not come to rest on the rear handlebar before the braking is at its maximum.
- the presence of safety pins.
- If the handlebars are «spongy» and the linings are new or in good condition, check and top up the fluid level in the brake master cylinder if necessary. Brake fluid is available in all cycle shops.
- Check that there is no fluid leakage from the hose at the brake lever or the caliper. In case of leakage or loss of pressure, contact a specialist.
- If you have to work on the hydraulic braking system, especially when changing the brake pads, we can supply you with a system bleeding kit.
- You will find between the brake pads, red, yellow or black plastic shims to be inserted between the two pads in case of disassembling the wheel and each time the Joëlette is folded.

It is recommended to always have a puncture-proof spray on each Joëlette (repair kit optional). It is strongly recommended that maintenance is carried out by a bicycle or motorbike repairer/renter.

CLEANING

When cleaning the Joëlette, please observe the following points:

- Use only a damp cloth and a mild, skin-friendly, non-toxic cleaning product..
- Do not use abrasive cleaning products.
- Do not expose the electronic components to direct contact with water (Joëlette eMotion).
- Do not use a high-pressure cleaner.
- As the cushion covers are thermally bonded, only clean the surface.

DISINFECTION

Disinfection using tested and recognised disinfectants on a wet cloth or by spraying is permitted. A list of currently approved disinfectants for wet wiping and spray cleaning can be found at the Robert Koch Institute at <http://www.rki.de>.

We recommend disinfecting the Joëlette (or Finisher, Kid, Sofao) before each use and at least between each different passenger to avoid the risk of cross-contamination.

INSPECTION CHECKS

The following tables provide a list of inspections that the user should carry out at the relevant intervals.

Before each use of the Joëlette

ELEMENTS	INSPECTION	IF UNSUCCESSFUL
SEAT LOCKING SYSTEM	Make sure that the movement of the locking lever is free without jamming and that the seat locks properly. To test this, brake while pushing on the handlebars	Contact us
	Make sure the locking lever is tight on the seat	Tighten the locking lever using 12 and 19 flat spanners
BATTERIES (JOËLETTE EMOTION)	Make sure the battery is charged. You will find an indication of the charge status on the top of the battery.	Charge the battery (see chapter «How to charge the battery»).
TIRE	Make sure that the tyre is not damaged and that there is no leakage at the inflation valve.	Contact us or get in touch with a cycle dealer.
	Make sure the tyre is inflated to the correct pressure.	Inflate the tyre. Refer to the main wheel tyre table in the «Technical data» chapter. To repair the inner tube, contact us or a bicycle dealer.
PRESENCE OF PINS AND SAFETY PINS	Make sure that each pin (shock absorber/frame/front leg/seat) is present in its housing and secured by the beta pin. In addition, check that the front arm safety pins are also present. We recommend changing safety pins and «beta» pins every 5 years.	Contact us
HARNESS AND ADDITIONAL PULL STRAP.	Make sure that the locking buckles do their job properly. Check that the seams or lashing karabiners are not damaged.	Contact us

BRAKING	Make sure the brake works.	Contact us
	Check that the lever on the handlebars is tight.	Retighten the lever
	Check that the brake hose loops are not broken or loose.	Contact us

Regularly

ELEMENTS	INSPECTION	EN CAS D'ÉCHEC
ALL PADDED PARTS	Check for damage and wear, especially on the seat cushion press studs and the Velcro strip that holds the backrest to the frame.	Contact us
BRAKING	Ensure that the brake pads are not excessively worn.	Contact us or get in touch with a cycle dealer.
	Check that the brake fluid level in the master cylinder is sufficient	Contact a cycle dealer.

LONG-TERM STORAGE

If you do not use your Joëlette for a long period of time, you should prepare it for storage in order to increase its life span and that of its battery (Joëlette eMotion).

We recommend storing the Joëlette at a temperature of 15°C and avoiding extreme temperatures in order to prolong its life and that of its accessories. The components are tested and approved for higher temperature ranges, detailed below:

- The permitted temperature range for storage of the vehicle is -40°C to +65°C.
- The permitted temperature range for storage of the battery (Joëlette eMotion) is between 0°C and +50°C
- The permitted temperature range for storage (eMotion) is 0°C to +40°C.

Even when not in use, the battery self-discharges. It is advisable to disconnect the battery pack from its holder if the e-Joëlette is stored for more than two weeks. The battery should always be fully charged before storage. If the battery is stored for more than four weeks, check its charge once a month and recharge it if necessary (before the gauge indicates that it is half charged) to avoid damage. Store in a dry, well-ventilated environment protected from external influences. Inflate the tyre slightly.

SHOCK ABSORBER ADJUSTMENT

Reminder of the concept of suspension

On a conventional suspension-damper combination, commonly known as a shock absorber, the suspension consists of a helical metal spring. On an oleopneumatic combination, the suspension (the elastic element) is provided by a volume of pressurised gas (air or nitrogen). This pressure is injected into the shock absorber by means of a high-pressure valve (available as an option - C10P170) fitted to the top fork of each unit. The initial inflation pressure determines the stiffness of the spring, and therefore the attitude of the Joëlette and the progressiveness of its depression.

- Thus, depending on the weight of the passenger and its use, its stiffness can be easily modified by simply changing the inflation pressure (pressurisation) recorded and noted in bars.

- Increasing the pressure increases the spring's stiffness, while decreasing the pressure reduces its stiffness.
- This pressure change is carried out using a suitable pump fitted with a screw-in connector which is connected to the valve.

Method for determining the pressure setting

- The Joëlette is fitted as standard with a handset pressurised to 13 bars for a passenger weight of 80kg, which compresses the handset by 15 to 18 mm, i.e. 1/3 of its total available travel of 50mm.
- Depending on the passenger's weight, the handset simply needs to be pressurised so that, when stationary, it measures a static depression of approximately 1/3 of its total travel.
- The appropriate pressure can be determined empirically by successive tests.

Inflation method

- Inflation is carried out using a manual pump fitted with a pressure gauge and a screw-in nozzle.
- Before connecting the pump, make sure that it can deliver a pressure higher than that of the handset.
- The inflation operation must be carried out with the Joëlette unloaded, i.e. without any support on the wheel.

Connecting the pump nozzle

Align the end cap with the valve. Screw it on until it is tight, applying a moderate tightening torque.

Note: Do not take into account the pressure indicated by the pressure gauge when connecting the pump, as some of the pressurised gas contained in the handset will be transferred to the pump, pressurising it to a lower pressure than that in the handset before connection.

- You simply have to carry out a new inflation operation and note the pressure displayed before disconnection. In fact, you cannot check the pressure in the handset by connecting a pump fitted with a pressure gauge.
- Inflate to the desired pressure read on the manometer, and when the needle stabilises, unscrew the nozzle.

The air that escapes when the pump is disconnected is contained in the pump hose. It does not affect the pressure in the handset, which is the pressure read on the manometer just before disconnection. Any vaporisation of oil at this point is completely normal.

Table given for information only:

Weight (Kg)	60	80	90	100
Pressure (bars)	13	16	18	20

Find out how to adjust the shock absorber pressure in pictures



AFTER USE

DISPOSAL

- The packaging of the appliances goes to material recycling.
- Metal parts go to scrap metal recycling.
- Plastic parts go to plastic recycling.
- Electrical parts and circuit boards go to electronic waste.
- Used or damaged batteries are taken back by competent local companies, ask your city or municipality administration.
- Waste management must be carried out in accordance with the relevant national legal regulations.

TECHNICAL DATA

The technical information provided in this document applies to the standard configuration for both models of Joëlette (Adventure and eMotion) or represents the theoretical maximum values. These characteristics may change if accessories are added.

Nb: Please note that in some cases, the measured values may vary by +/- 10mm.

AUTHORISED CONDITIONS AND PLACES OF USE AND STORAGE	
OPERATING TEMPERATURE RANGE	de -10°C à +40°C
RECOMMENDED STORAGE TEMPERATURE	15°C
STORAGE TEMPERATURE RANGE	from 0°C à +40°C with batteries from -40°C à +65°C without batteries

ELECTRICAL SYSTEM	
ENGINE	1 x 250 W open, motorised
BATTERIES	36 V/ 10 Ah/ Lithium Ion MnCoO2
POWER FUSE	30A automotive type mini jumper fuse
LOAD FUSE	10A automotive type mini jumper fuse
DEGREES OF PROTECTION	IP64

CHARGING DEVICE	
NOMINAL OUTPUT CURRENT	3A
MAXIMUM OUTPUT CURRENT	4A
OUTPUT VOLTAGE	36V

TIRE	
TIRE TYPE	20" x 4" tire
TIRE PRESSION	The maximum recommended inflation pressure for the tyre in bar or kPa is indicated on the inner wall of the tyre. If several values are indicated, the lowest value in the corresponding unit applies.

DRIVING CHARACTERISTICS

SPEED	Max 5 Km/h with assistance (Joëlette eMotion)
BRAKING DISTANCE	1 m at 5 Km/h (Joëlette eMotion)
AUTONOMY	Between 3 and 5h Joëlette eMotion

DIMENSIONS	JOËLETTE ADVENTURE (WITHOUT HEADREST)	JOËLETTE EMOTION (WITHOUT HEADREST)
TOTAL HEIGHT	1248 mm	1248 mm
TOTAL WIDTH	616 mm	616 mm
TOTAL LENGTH	2380 mm	2380 mm
ROLLING SEAT HEIGHT	784 mm in the middle of the cushion	784 mm in the middle of the cushion
SEAT HEIGHT TRANSFER	480 mm	480 mm
SEAT WIDTH	480 mm	480 mm
SEAT DEPTH	382 mm	382 mm
MINIMUM SEAT THICKNESS	70 mm	71 mm
BACKREST HEIGHT	480 mm	480 mm
MIN. BACKREST THICKNESS	60 mm	60 mm
BACKREST ANGLE	94 / 105 / 118 °	94 / 105 / 118 °
SEAT ANGLE	5°	5°
ARMREST HEIGHT	170 mm	170 mm
ARMREST LENGTH	210 mm	210 mm
DISTANCE FOOTREST / SEAT	from 425 mm to 180 mm	from 425 mm to 180 mm
GROUND CLEARANCE	318 mm	318 mm
SEAT SIZE	970(L) x 630(W) x 410(H)	970(L) x 630(W) x 410(H)

	JOËLETTE ADVENTURE (WITHOUT HEADREST)	JOËLETTE EMOTION (WITHOUT HEADREST)
TARE WEIGHT	26 Kg	29.5 Kg
MAXIMUM CHARGE	110 Kg	110 Kg

CUSHIONS COMPOSITION	
UPPER SIDE	100% Polyester
FOAM	Polyurethane
BOTTOM OF SEAT AND BACK OF BACK	88% flame-retardant PVC on 12% polyester/cotton

SPECIFIC INFORMATION

- The expected life of the products is 8 years.
- The products have been mechanically tested in accordance with standard EN 21856-2022 using a dummy weighing of 110 kg.
- The Joëlette eMotion has undergone electrical safety tests in accordance with IEC 60601-1 : 2005 and electro-magnetic compatibility tests in accordance with IEC 60601-1-2 : 2014 / AI : 2020. The mechanical tests applied to the components containing the electrical parts were carried out using a 135 kg dummy.
- On the Joëlette eMotion, the applied parts are BF type.

ASSEMBLY OF THE HEADREST



1. Attach the plastic flange to the back of the backrest using the screws provided.

2. Screw the knob loosely into place.



3. Slide the headrest into its housing on the back of the backrest.



4. Tighten the knob to secure the headrest.

Be cautious of hand trapping and pinching.

Watch the video here



ASSEMBLY OF THE ADVERTISING SUPPORTS



1. Position the plate on the outside of the armrest.



2. Insert the nuts into their dedicated recesses on the inside of the armrest.



3. Screw in the screws from the outside in front of each nut.

For mounting the side bags, proceed in the same manner. The model is universal; there is no right or left.

Be cautious of hand trapping and pinching.



Joëlette and Co
by Ferriol-Matrat

The pictograms below can be found in this user manual and on the product label:



Complies with the essential requirements of the European legislation applicable to the product.



Warning: it is imperative to consult the user manual



Warning: it is imperative to consult the user manual



This marking indicates that within the EU this product must not be disposed of with household waste. In order to prevent possible damage to the environment or human health due to uncontrolled disposal, recycle this appliance responsibly to encourage the sustainable reuse of materials. To return your used appliance, use the return and collection systems or contact the retailer from whom you purchased the product. They will be able to recycle this product in an environmentally friendly way.



Catalogue reference



Manufacturer



YYYY-MM Date of manufacture (Year-Month)



Batch number



Serial number



Direct current



Type BF applied part

To find the latest version of the instructions, go to our website



CONTACT

**PLEASE DO NOT HESITATE TO CONTACT THE JOËLETTE AND CO
TEAM FOR ANY QUESTION**



export@joëletteandco.com

AFTER SALES : jc-odin@joëletteandco.com



0033 (0)4 - 77 - 42 - 62 - 58

JOIN THE JOËLETTE'S COMMUNITY ON SOCIAL NETWORKS!



@FERRIOL-MATRAT - ALL RIGHTS RESERVED

This manual is protected by the law of 11 March 1957 on literary and artistic property, supplemented by the law of 3 July 1985 and by all conventions applicable to copyright. In application of these laws and conventions, no reproduction, total or partial copy of the manual, programs or systems is authorised without the prior written consent of FERRIOL-MATRAT. FERRIOL-MATRAT reserves the right to revise and improve these products. This publication describes the state of the product at the time of publication and does not prejudge any changes that may be made to it.